

LEW

Installation, use and maintenance manual

GB



Reversible Chillers and Heat Pumps - LEW SERIES

40 - 420 kW

CE

TABLE OF CONTENTS

1. GENERAL DESCRIPTION.....	4
1.1 The Series.....	4
1.2 Structure	4
1.3 Field of Application.....	4
1.4 Cooling circuit	4
2. PRELIMINARY PROCEDURES.....	10
2.1 Inspection on receipt.....	10
2.2 Lifting and Conveyance	10
2.3 Overall dimensions and weight.....	10
2.4 Unpacking	11
2.5 Siting	12
3. INSTALLATION	13
3.1 Installation clearance requirements	13
3.2 General Guidelines for Plumbing Connections	13
3.3 Water connection to the evaporator.....	14
3.4 Instructions for the filling up of the tank and/or the pump(s) (<i>if present</i>).....	15
4. ELECTRICAL CONNECTIONS	16
4.1 Generalities.....	16
4.2 Electrical connections of the circulation pump (<i>if present</i>).....	16
4.3 Remote controls.....	16
4.4 Summer Winter Remote Switching [Heat pump version].....	16
5. STARTING UP	17
5.1 Preliminary checks.....	17
5.2 Start-up instructions for LEW water chillers	17
5.3 Starting operation.....	18
5.4 Checks during operation	19
5.5 Checking the refrigerant level	19
5.6 Stopping the unit.....	20
6. OPERATING LIMITS	20
6.1 Glycol solutions.....	20
6.2 Operating limits	21
6.3 Water flow to the evaporator.....	21
7. SETTING OPERATING PARAMETERS.....	21
7.1 Generalities.....	21
7.2 Maximum pressure switch.....	22
7.3 Minimum pressure switch.....	22
7.4 Service thermostat	22
7.5 Antifreeze thermostat.....	22
7.6 Anti-recycle timer	23
8. MAINTENANCE	23
8.1 Warnings.....	23
8.2 Generalities.....	23
8.3 Repairing the Cooling Circuit	24
8.4 Tightness test.....	25
8.5 Hard Vacuum and Drying of Cooling Circuit	25
8.6 Recharging with refrigerant R410A.....	25
8.7 Environmental protection	26
9. TROUBLESHOOTING	26



Declaration of conformity

The declaration of conformity is attached to the documentation put into each unit sold.

For further information or communication, please contact the company at: info@galletti.it

Water Chillers and heat pumps are in accordance with the law 97/23/CE (PED) filling in D1 form, approved by the third notified body ICIM N° 0425.

1. GENERAL DESCRIPTION

1.1 The Series

The LEW series of water-condensing chillers includes a range of models capable of satisfying every need.

- LEW C water-water chillers – cooling only – refrigerant R410A
- LEW H water-water chillers – heat pump version – refrigerant R410A

1.2 Structure

All LEW units have a galvanised sheet steel supporting base, coated with epoxy polyester powder paint oven cured at 180°C. The unit features an exclusive design which lends it an attractive appearance as well as ensuring that all components will be completely inaccessible when the unit is closed. This characteristic, together with the extensive use of soundproofing material inside the compartment – an optional feature of low-noise models – reduces noise to exceptionally low levels [Lp < 66 dB-A @1 metre]. The plumbing/cooling connections are situated at the top to reduce the technical spaces required for installation. All panels are removable, thus enabling complete access to all components of the chiller, though only access from the front is required for routine servicing.

1.3 Field of Application

The LEW units are designed to cool-heat water and solutions containing up to 35% glycol (percentage by weight) in civil, industrial and technological air-conditioning systems. In buildings with large surface areas, the air conditioning system can be expanded step by step as new floors or areas are sold/leased, by installing a LEW unit for every floor in a small control room. This allows you to spread your investment over time. The possibility of keeping the evaporator indoors means there is no need to add glycol to the water inside the system. In addition, you can keep all components requiring routine or special maintenance in an easily accessible room. The pluses offered by these products are summed up in the following table:

- LEW C-H water-condensing units
 - Occupies an extremely small surface area
 - No need to add glycol to the water in the user circuit
 - High COP [Coefficient of Performance] of the thermodynamic cycle
 - No noise outside
 - Extremely small refrigerant charge.
 - Innovative aesthetics and total safety, given that the chillers are completely enclosed
 - Option of installing an outdoor dry cooler where it is not possible to use a non-recirculating water supply to cool the condenser
 - Heat pump version with cycle reversibility at the cooling side
 - Condensing control option on the heat pump versions possible

LEW C-H units are to be used within the operating limits stated in this manual; failure to comply with said limits will invalidate the warranties provided in the contract of sale.

Do not install the unit in environments with gas or flammable dusts.

1.4 Cooling circuit

The entire cooling circuit is built in the manufacturer factory using only components of the finest quality brands and processes conforming to the specifications of Directive 97/23 for brazing. The chillers are built with a single cooling circuit using only components supplied by leading international manufacturers.

- Compressors: only scroll-type compressors of leading international manufacturers are used in the LEW units. The scroll compressor is presently the best solution in terms of reliability and efficiency in the range of power up to 182 kW for each circuit and in terms of noise level. **NOTE**: the scroll compressor, like all hermetic compressors, is classified as a pressure vessel according to the PED insofar as its low-pressure section is concerned, to which the PS indicated on the rating plate refers.
- Heat exchangers all chillers have heat exchangers with braze-welded AISI 304 austenitic stainless steel plates and connections made of AISI 304 L, characterised by a reduced carbon content to facilitate brazing. Braze-welded plate exchangers represent the state of the art in terms of heat exchange efficiency and make it possible to significantly reduce the refrigerant charge compared to traditional solutions. The high turbulence induced by the internal corrugation of the plates combined with their perfectly smooth surface also helps prevent dirt build-up and the formation of scale on the condenser side. **NOTE**: due to the presence of heat insulation, the data plate is not legible as required under 97/23 PED. However, the exchanger serial number and declaration of conformity are recorded during production and constitute an integral part of Galletti S.p.A records.
- Cooling components:
 - Molecular mesh activated-alumina filter dryer.
 - Flow indicator with humidity indicator. Indications are provided directly on the sight glass.
 - Thermostatic valve with external equalisation and integrated MOP function.
 - Thermostatic el. valve with step by step engine and dedicated el.driver to obtain the maximum efficiency of the cooling circuit and the best optimization of the functioning parameters.
 - Reverse cycle valve (heat pump only).
 - Unidirectional valve (heat pump only).
 - High and low pressure switches.
 - Schrader valves for checks, access and/or maintenance.
 - Safety valve refrigerating side.
- Electric control board: The electric control board is constructed and wired in accordance with Directives 73/23/EEC and 89/336/EEC and related standards. The board may be accessed through a door after the main switch has been put off. All the remote controls use 24 V signals powered by an insulating transformer situated on the electric control board. A T control kit comprising a thermostat and an auxiliary fan is available on request. The protection rating of the unit is IP 43. **NOTE**: the mechanical safety devices such as the high pressure switch are of the kind that trigger directly; their efficiency will not be affected by any faults occurring in the microprocessor control circuit. in compliance with 97/23 PED.
- Control microprocessor: the microprocessor built into the unit allows the different operating parameters to be controlled from a set of pushbuttons situated on the electric control board:
 - Switching on/off of compressor to maintain the temperature set point of the chiller inlet water temperature.
 - Alarm management:
 - High / low pressure;
 - Antifreeze;
 - Flow switch;
 - Pump alarm.
 - Alarm signalling.
 - Display of operating parameters.
 - Antifreeze protection of evaporator.
 - Management of maximum number of compressor start-ups.
 - RS232, RS485 serial output management (optional).
 - Phase sequence error [Not displayed by the mP, but prevents the compressor from starting up].

[ref. Microprocessor control manual for further details]

BASIC COOLING CIRCUIT

- ❑ **Cooling only versions** (NB: Basic diagram – please refer to the drawing attached to the documentation of the unit)

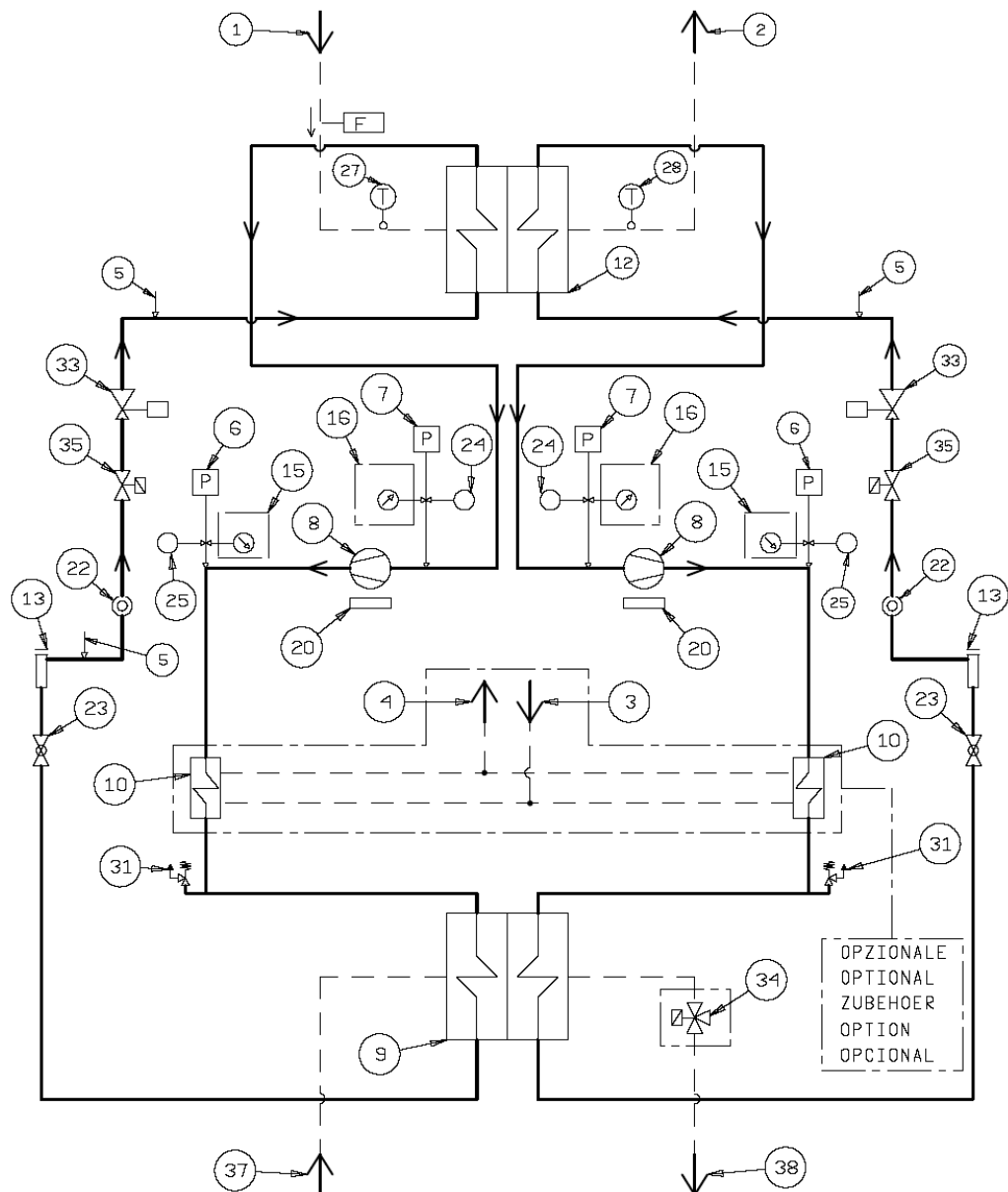

ITALIANO	ENGLISH
1 INGRESSO ACQUA REFRIGERATA	1 CHILLED WATER INLET
2 USCITA ACQUA REFRIGERATA	2 CHILLED WATER OUTLET
3 INGRESSO ACQUA DESURRISCALDATA	3 DE-SUPERHEATER WATER INLET
4 USCITA ACQUA DESURRISCALDATORE	4 DE-SUPERHEATER WATER OUTLET
5 ATTACO DI CARICA	5 CHARGE CONNECTION
6 PRESSOSTATO DI ALTA	6 HIGH PRESSURE SWITCH
7 PRESSOSTATO DI BASSA	7 LOW PRESSURE SWITCH
8 COMPRESSORE	8 COMPRESSOR
9 CONDENSATORE	9 CONDENSER
10 DESURRISCALDATORE	10 DE-SUPERHEATER
11 SERBATOIO DI ACCUMULO	11 BUFFER TANK
12 EVAPORATORE	12 EVAPORATOR
13 FILTRO DEIDRATORE	13 FILTER DRYER
14 FLUSSOSTATO	14 FLOW SWITCH
15 MANOMATRO ALTA PRESSIONE	15 HIGH PRESSURE MANOM.
16 MANOMETRO BASSA PRESSIONE	16 LOW PRESSURE MANOM.
17 MOTOVENTILATORE	17 FAN MOTOR
18 POMPA CIRCOLAZIONE ACQUA REFRIGERATA	18 CHILLED WATER PUMP
19 SARACINESCA	19 GATE VALVE
20 RESISTENZA CARTER	20 CRANKCASE HEATER
21 RADIATORE ENERGY - SAVING	21 ENERGY - SAVING COIL
22 SPIA DI FLUSSO	22 SIGHT GLASS
23 RUBINETTO A SFERA	23 SHUT-OFF VALVE
24 SONDA PRESSIONE EVAPORAZIONE	24 EVAPORATING PRESSURE PROBE
25 SONDA PRESSIONE CONDENSAZIONE	25 CONDENSING PRESSURE PROBE
26 VASO DI ESPANSIONE	26 EXPANSION TANK
27 SONDA TEMPERATURA INGRESSO ACQUA	27 WATER INLET TEMPERATURE SENSOR
28 SONDA TEMPERATURA USCITA ACQUA	28 WATER OUTLET TEMPERATURE SENSOR
29 SONDA TEMPERATURA ARIA ESTERNA	29 EXTERNAL AIR TEMPERATURE SENSOR
30 VALVOLA DI RITEGNO	30 CHECK VALVE
31 VALVOLA DI SICUREZZA	31 SAFETY VALVE
32 VALVOLA DI SICUREZZA ACQUA	32 WATER SAFETY VALVE
33 VALVOLA TERMOSTATICA	33 THERMOSTATIC VALVE
34 VALVOLA FREE-COOLING	34 FREE-COOLING VALVE
35 ELETTROVALVOLA DEL LIQUIDO	35 SOLENOID VALVE
36 ELETTROVALVOLA PARZIALIZZAZIONE	36 PARTIALIZATION SOLENOID VALVE
37 USCITA ACQUA CONDENSATA	37 CONDENSING WATER OUTLET
38 INGRESSO ACQUA CONDENSATA	38 CONDENSING WATER INLET
39 VALVOLA QUATTRO VIE	39 4-WAY-VALVE
40 RICEVITORE DEL LIQUIDO	40 LIQUID RECEIVER
41 VALVOLA ESPANSIONE ELETTRONICA	41 ELECTRONIC EXPANSION VALVE

- **Heat pump versions** (NB: Basic diagram – please refer to the drawing attached to the documentation of the unit)

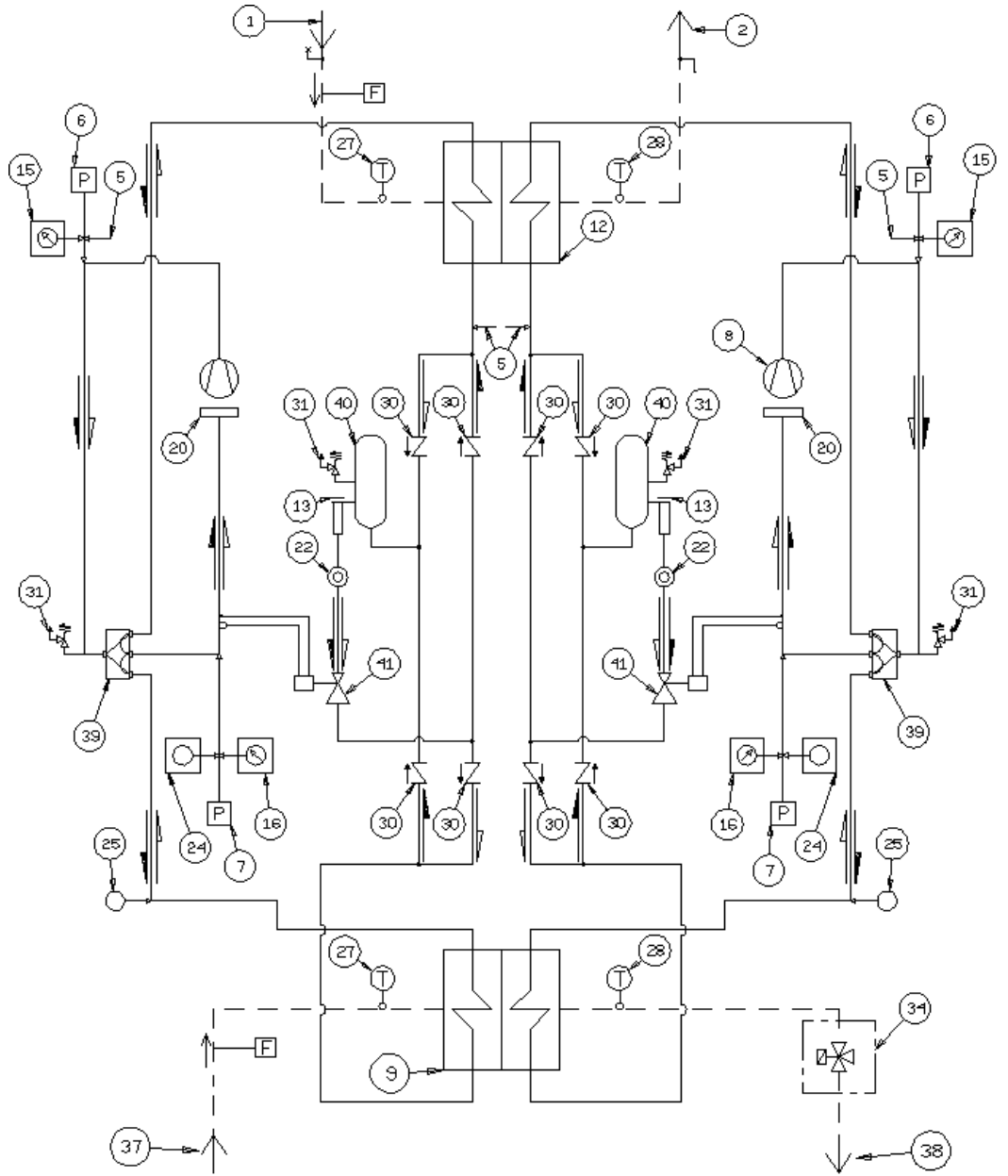

ITALIANO	ENGLISH
1 INGRESSO ACQUA REFRIGERATA	1 CHILLED WATER INLET
2 USCITA ACQUA REFRIGERATA	2 CHILLED WATER OUTLET
3 INGRESSO ACQUA DESURRISCALDATA	3 DE-SUPERHEATER WATER INLET
4 USCITA ACQUA DESURRISCALDATORE	4 DE-SUPERHEATER WATER OUTLET
5 ATTACO DI CARICA	5 CHARGE CONNECTION
6 PRESSOSTATO DI ALTA	6 HIGH PRESSURE SWITCH
7 PRESSOSTATO DI BASSA	7 LOW PRESSURE SWITCH
8 COMPRESSORE	8 COMPRESSOR
9 CONDENSATORE	9 CONDENSER
10 DESURRISCALDATORE	10 DE-SUPERHEATER
11 SERBATOIO DI ACCUMULO	11 BUFFER TANK
12 EVAPORATORE	12 EVAPORATOR
13 FILTRO DEIDRATORE	13 FILTER DRYER
14 FLUSSOSTATO	14 FLOW SWITCH
15 MANOMATRO ALTA PRESSIONE	15 HIGH PRESSURE MANOM.
16 MANOMETRO BASSA PRESSIONE	16 LOW PRESSURE NANOM.
17 MOTOVENTILATORE	17 FAN MOTOR
18 POMPA CIRCOLAZIONE ACQUA REFRIGERATA	18 CHILLED WATER PUMP
19 SARACINESCA	19 GATE VALVE
20 RESISTENZA CARTER	20 CRANKCASE HEATER
21 RADIATORE ENERGY - SAVING	21 ENERGY - SAVING COIL
22 SPIA DI FLUSSO	22 SIGHT GLASS
23 RUBINETTO A SFERA	23 SHUT-OFF VALVE
24 SONDA PRESSIONE EVAPORAZIONE	24 EVAPORATING PRESSURE PROBE
25 SONDA PRESSIONE CONDENSAZIONE	25 CONDENSING PRESSURE PROBE
26 VASO DI ESPANSIONE	26 EXPANSION TANK
27 SONDA TEMPERATURA INGRESSO ACQUA	27 WATER INLET TEMPERATURE SENSOR
28 SONDA TEMPERATURA USCITA ACQUA	28 WATER OUTLET TEMPERATURE SENSOR
29 SONDA TEMPERATURA ARIA ESTERNA	29 EXTERNAL AIR TEMPERATURE SENSOR
30 VALVOLA DI RITEGNO	30 CHECK VALVE
31 VALVOLA DI SICUREZZA	31 SAFETY VALVE
32 VALVOLA DI SICUREZZA ACQUA	32 WATER SAFETY VALVE
33 VALVOLA TERMOSTATICA	33 THERMOSTATIC VALVE
34 VALVOLA CONTROLLO CONDENSAZIONE	34 CONDENSING CONTROL VALVE
35 ELETTROVALVOLA DEL LIQUIDO	35 SOLENOID VALVE
36 ELETTROVALVOLA PARZIALIZZAZIONE	36 PARTIALIZATION SOLENOID VALVE
37 INGRESSO ACQUA CONDENSATA	37 CONDENSING WATER INLET
38 USCITA ACQUA CONDENSATA	38 CONDENSING WATER OUTLET
39 VALVOLA QUATTRO VIE	39 4-WAY-VALVE
40 RICEVITORE DEL LIQUIDO	40 LIQUID RECEIVER
41 VALVOLA ESPANSIONE ELETTRONICA	41 ELECTRONIC EXPANSION VALVE

2. PRELIMINARY PROCEDURES

2.1 Inspection on receipt

On receiving the unit, check that it is perfectly intact: the machine left the factory in perfect conditions; immediately report any signs of damage to the carrier and note them on the Delivery Slip before signing it.

Galletti S.p.A. or its Agent must be promptly notified of the entity of the damage.

The Customer must submit a written report describing every significant sign of damage.

2.2 Lifting and Conveyance

While the unit is being unloaded and positioned, utmost care must be taken to avoid abrupt or violent manoeuvres. The unit must be handled carefully and gently: avoid using machine components as anchorages when lifting or moving it.

The unit must be lifted using steel pipes $\varnothing 1\frac{1}{2}$ " GAS, almost 3mm of thickness, inserted through the holes provided on the base frame (see fig. below) and signed with appropriate stickers.

Use ropes or belts of adequate length and strength and spacer bars to avoid damaging the sides and top of the unit.



Warning: In all lifting operations make sure that the unit is securely anchored in order to prevent accidental falls or overturning.

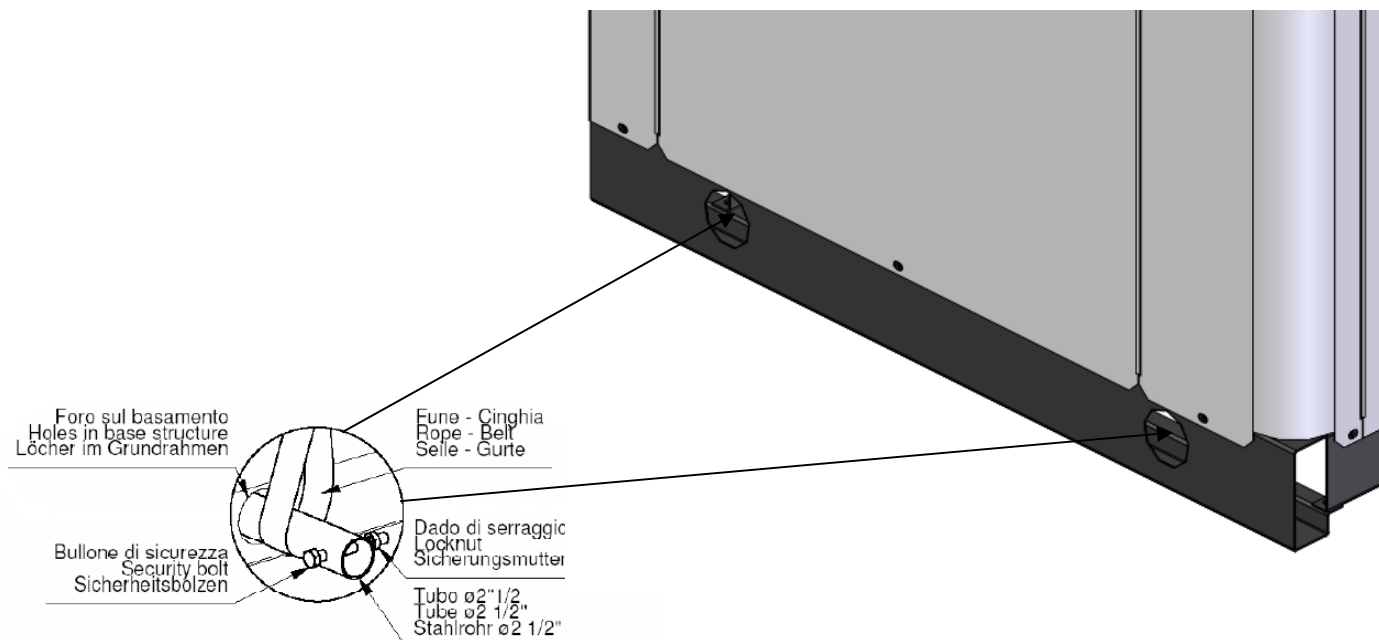

2.3 Overall dimensions and weight

The LEW product range consists in different frames. In the following paragraph, the overall drawings of the LEW models and their optional modules are attached. They can be referred to directly when consulting the identification codes carried in the tables in this paragraph. The tables below list the weights, reference drawings and overall dimensions of all the LEW models as well as their optional hydraulic modules. The overall drawings of reference are displayed in the following paragraph.

Table VI: weight and reference drawings of main units of the LEW range, in reference to their frames

Frame	Model	CS - Chiller		DS Chiller Dry Cooler		HS – Heat Pump		WS – Hot only	
		Weight [kg]	Overall Drawing	Weight [kg]	Overall Drawing	Weight [kg]	Overall Drawing	Weight [kg]	Overall Drawing
F1	LEW 041	370	HF64000737	370	HF64000737	415	HF64000737	370	HF64000614
	LEW 042	360	HF64000737	360	HF64000737	385	HF64000737	360	HF64000614
	LEW 051	430	HF64000737	430	HF64000737	475	HF64000737	430	HF64000614
	LEW 052	420	HF64000737	420	HF64000737	445	HF64000737	420	HF64000614
	LEW 061	440	HF64000737	447	HF64000737	502	HF64000737	447	HF64000614
	LEW 062	430	HF64000737	437	HF64000737	467	HF64000737	437	HF64000614
	LEW 071	450	HF64000737	457	HF64000737	512	HF64000737	457	HF64000614
	LEW 072	440	HF64000737	447	HF64000737	482	HF64000737	447	HF64000614
	LEW 081	470	HF64000737	485	HF64000737	530	HF64000737	485	HF64000614
	LEW 082	460	HF64000737	475	HF64000737	510	HF64000737	475	HF64000614
F2	LEW 091	510	HF64000737	525	HF64000737	575	HF64000737	525	HF64000614
	LEW 092	490	HF64000737	505	HF64000737	540	HF64000737	505	HF64000614
	LEW 111	560	HF64000592	585	HF64000592	645	HF64000592	585	HF64000608
	LEW 112	550	HF64000592	575	HF64000592	605	HF64000592	575	HF64000608
	LEW 131	570	HF64000592	595	HF64000592	660	HF64000592	595	HF64000608
	LEW 132	560	HF64000592	585	HF64000592	625	HF64000592	585	HF64000608
	LEW 141	630	HF64000592	650	HF64000592	720	HF64000592	650	HF64000608
	LEW 142	615	HF64000592	635	HF64000592	685	HF64000592	635	HF64000608
	LEW 161	670	HF64000592	705	HF64000592	775	HF64000592	705	HF64000608
	LEW 162	650	HF64000592	685	HF64000592	740	HF64000592	685	HF64000608
F3	LEW 181	710	HF64000592	750	HF64000592	825	HF64000592	750	HF64000608
	LEW 182	690	HF64000592	730	HF64000592	780	HF64000592	730	HF64000608
	LEW 144	720	HF64000581	740	HF64000581	830	HF64000581	740	HF64000802
	LEW 164	740	HF64000581	775	HF64000581	865	HF64000581	775	HF64000802
	LEW 184	850	HF64000581	890	HF64000581	985	HF64000581	890	HF64000802
F4	LEW 204	870	HF64000581	915	HF64000581	1110	HF64000581	915	HF64000802
	LEW 214	920	HF64000581	965	HF64000581	1065	HF64000581	965	HF64000802
	LEW 243	950	HF64000581	1060	HF64000609	1120	HF64000609	1060	HF64000627
	LEW 244	980	HF64000581	1090	HF64000609	1270	HF64000609	1090	HF64000627
	LEW 283	1050	HF64000803	1120	HF64000609	1180	HF64000609	1120	HF64000627
	LEW 284	1090	HF64000803	1260	HF64000609	1340	HF64000609	1260	HF64000627
	LEW 314	1250	HF64000803	1330	HF64000609	1420	HF64000609	1330	HF64000627
	LEW 344	1290	HF64000803	1380	HF64000609	1470	HF64000609	1380	HF64000627
	LEW 374	1330	HF64000803	1440	HF64000609	1540	HF64000609	1440	HF64000627
	LEW 424	1410	HF64000803	1530	HF64000609	1650	HF64000609	1530	HF64000627

Table VIII: weight and reference drawings of optional modules, in reference to dimensions of relative main unit and whether or not there is a water side cycle inversion valve.

Model	Optional hydraulic module with pumps			Optional hydraulic module with pumps and cycle inversion valves		
	Frame of optional module	Weight [kg]	Overall Drawing	Frame of optional module	Weight [kg]	Overall Drawing
LEW 041	M1	391	HF64000836	M2	491	HF64000900
LEW 042	M1	391	HF64000836	M2	491	HF64000900
LEW 051	M1	400	HF64000836	M2	500	HF64000900
LEW 052	M1	400	HF64000836	M2	500	HF64000900
LEW 061	M1	400	HF64000836	M2	500	HF64000900
LEW 062	M1	400	HF64000836	M2	500	HF64000900
LEW 071	M1	395	HF64000836	M2	495	HF64000900
LEW 072	M1	395	HF64000836	M2	495	HF64000900
LEW 081	M1	395	HF64000836	M2	495	HF64000900
LEW 082	M1	395	HF64000836	M2	495	HF64000900
LEW 091	M1	399	HF64000836	M2	499	HF64000900
LEW 092	M1	399	HF64000836	M2	499	HF64000900
LEW 111	M1	399	HF64000836	M2	499	HF64000900
LEW 112	M1	399	HF64000836	M2	499	HF64000900
LEW 131	M1	412	HF64000836	M2	512	HF64000900
LEW 132	M1	412	HF64000836	M2	512	HF64000900
LEW 141	M1	412	HF64000836	M2	512	HF64000900
LEW 142	M1	412	HF64000836	M2	512	HF64000900
LEW 161	M1	433	HF64000836	M2	533	HF64000900
LEW 162	M1	433	HF64000836	M2	533	HF64000900
LEW 181	M1	543	HF64000836	M2	643	HF64000900
LEW 182	M1	543	HF64000836	M2	643	HF64000900
LEW 144	M3	423	HF64000901	M4	523	HF64000900
LEW 164	M3	433	HF64000901	M4	533	HF64000903
LEW 184	M3	543	HF64000901	M4	643	HF64000903
LEW 204	M3	559	HF64000902	M4	659	HF64000903
LEW 214	M3	559	HF64000902	M4	659	HF64000904
LEW 243	M3	576	HF64000902	M4	676	HF64000904
LEW 244	M3	587	HF64000902	M4	687	HF64000904
LEW 283	M3	587	HF64000902	M4	687	HF64000904
LEW 284	M3	587	HF64000902	M4	687	HF64000904
LEW 314	M3	614	HF64000902	M4	714	HF64000904
LEW 344	M3	614	HF64000902	M4	714	HF64000904
LEW 374	M3	626	HF64000902	M4	726	HF64000904
LEW 424	M3	626	HF64000902	M4	726	HF64000904

2.4 Unpacking

The packing must be carefully removed to avoid the risk of damaging the unit. Different packing materials are used: wood, cardboard, nylon, etc.

It is recommended to keep them separately and deliver them to suitable waste disposal or recycling facilities in order to minimise their environmental impact.

2.5 Siting

You should bear in mind the following aspects when choosing the best site for installing the unit and the relative connections:

- size and origin of water pipes;
- location of power supply;
- accessibility for maintenance or repairs;
- solidity of the supporting surface.

All models belonging to the LEW series are designed and built for indoor installation. As special care has been taken in the sound insulation and sealing of the components and hot parts in general, they need not be installed in dedicated rooms.

It is advisable to place a rigid rubber strip between the base frame and the supporting surface.

3. INSTALLATION

3.1 Installation clearance requirements

In the case of units with a remote condenser, the plumbing and cooling connections are provided on the top of the unit. This allows the chiller to be placed practically against the rear wall. It is nonetheless of fundamental importance to assure the following service spaces:

- back side: min. 0 metres (except the 2 last sizes)
- electric control board side: min. 1.0 metre to guarantee access for inspection and/or maintenance of cooling components
- lateral part: min. 0.5 metre for extraordinary maintenance
- top side: min. 1.0 metre for adequate connection to the external hydraulic and cooling piping.

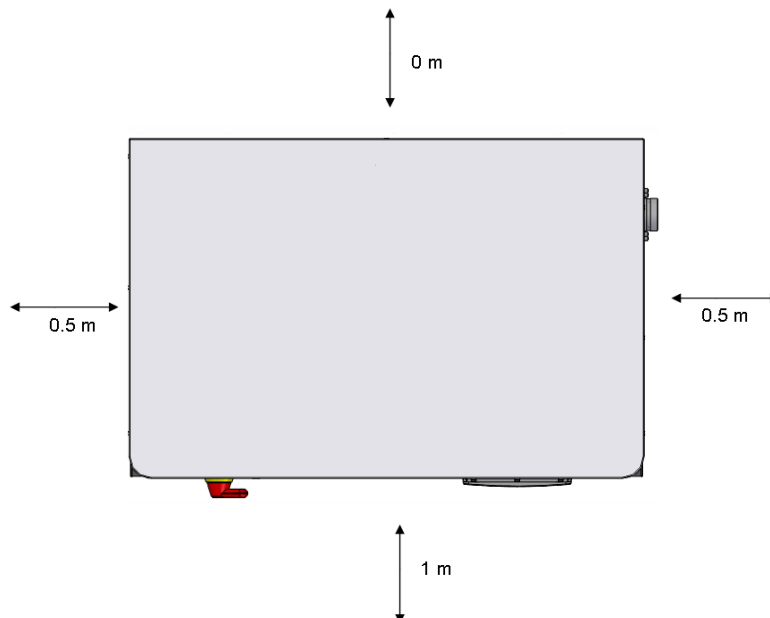

3.2 General Guidelines for Plumbing Connections

When you are getting ready to set up the water circuit you should follow the directions below and in any case make sure you comply with national or local regulations (use the diagrams included in this manual as your reference).

- Connect the pipes to the chiller using flexible couplings to prevent the transmission of vibrations and to compensate thermal expansions. For the types and size of the water and cooling connections [versions with remote condenser only] refer to the table of technical data.
- It is recommended to install the following components on the pipes:
 - temperature and pressure indicators for routine maintenance and monitoring of the unit. Checking the pressure on the water side will enable you to verify whether the expansion tank is working efficiently and to promptly detect any water leaks within the equipment.

- traps on incoming and outgoing pipes for temperature measurements, which can provide a direct reading of the operating temperatures. Temperature readings can in any case be obtained from the microprocessor installed on the unit.
- regulating valves (gate valves) for isolating the unit from the water circuit during maintenance work.
- metal filters (piping input) with a mesh size not exceeding 1 mm, to protect the exchanger from slag or impurities present in the pipes. This requirement is especially important at the first start.
- air vent valves, to be placed at the highest points of the water circuit for the purpose of bleeding air. [The internal pipes of the unit are fitted with small manual air vent valves for bleeding the unit itself: **this operation may only be carried out when the unit is disconnected from the power supply**].
- drainage valve and, where necessary, a drainage tank for emptying out the equipment for maintenance purposes or when the unit is taken out of service at the end of the season.



3.3 Water connection to the evaporator



N.B.: all LEW units are not provided with an internal water group, but it will be installed on the outside of the unit.



It is of fundamental importance that the incoming water supply is hooked up to the connection marked "Water Inlet".

Otherwise the evaporator would be exposed to the risk of freezing since the antifreeze thermostat would not be able to perform its function; moreover the reverse cycle would not be respected in the cooling mode, resulting in additional risks of malfunctioning. This position does not enable the operation of the water flow control device.

The dimensions and position of plumbing connections are shown in the dimension tables at the end of the manual.



The water circuit must be set up in such a way as to guarantee that the nominal flow rate of the water supplied to the evaporator remains constant (+/- 15%) in all operating conditions.

The compressors work intermittently, since the chilling requirements of the user generally do not coincide with the compressor output. In systems containing little water, where the thermal inertia of the water is lower, it is a good idea to check that the water content in the section delivering to users satisfies the condition below:

$$V = \frac{C_c \times \Delta \tau}{\rho \times Sh \times \Delta T \times N_s}$$

V	= water content in user section	[m ³]
Sh	= specific heat of the fluid	[J/(kg°C)]
ρ	= fluid density	[kg/m ³]
D τ	= minimum time lapse between 2 compressor restarts	[s]
DT	= allowed water T differential	[°C]
Cc	= Cooling capacity	[W]
Ns	= N° of capacity control steps	

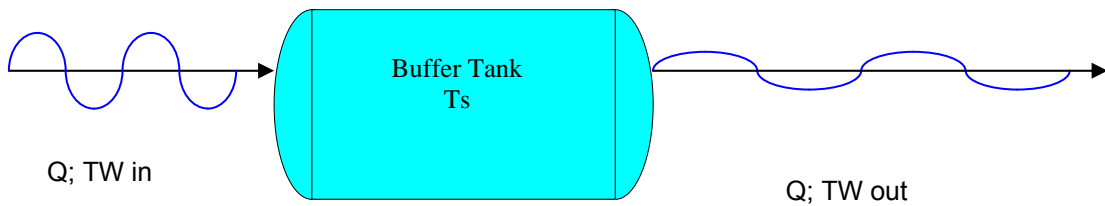

A **standard** feature of LEW units is a device for controlling the flow rate (flow switch or differential pressure switch) in the water circuit in the immediate vicinity of the evaporator. Any tampering with said device will immediately invalidate the warranty. It is advisable to install a metal mesh filter on the inlet water pipe.



Warning: When making the plumbing connections, make sure there are no open flames in proximity to or inside the unit.

3.4 Instructions for the filling up of the tank and/or the pump(s) (if present)



The tank is not planned to resist to a depression greater than -0,15 Bar, so pay attention to the fact that the suction pressure of the pump, where the expansion tank is positioned, has to be always greater than 0,5 Bar with the pump in operation: this fact also contributes to reduce any risks concerning the cavitation of the pump.

It is of fundamental importance for the installer to follow and check the instructions written below stepwise, so as to avoid every kind of risks concerning the implosion of the tank or the cavitation of the pump:

- a) Empty the expansion tank until the pressure is 0,5 Bar
- b) Charge the system and pressurize it until about + 1 Bar in suction, pump side (with pump not working)
- c) Allow air to escape from the system
- d) Check the suction pressure of the pump (about 1 Bar) and start the system
- e) Stop the pump after 15-30 minutes and repeat from point **c**) until you don't hear noises, caused by air still present in the system, anymore.

4. ELECTRICAL CONNECTIONS

4.1 Generalities



Before carrying out any job on electrical parts, make sure the power supply is disconnected.

Check that the mains electricity supply is compatible with the specifications (voltage, number of phases, frequency) shown on the unit rating plate.

The power connection for single-phase loads is to be made with a three-pole cable and "N" wire at the centre of the star [optional: power supply w/o neutral].



The size of the cable and line protections must conform to the specifications provided in the wiring diagram.

The supply voltage may not undergo fluctuations exceeding $\pm 5\%$ and the unbalance between phases must always be below 2%.



The above operating conditions must always be complied with: failure to ensure said conditions will result in the immediate invalidation of the warranty.

The electrical connections must be made in accordance with the information shown in the wiring diagram provided with the unit and current regulations.

An earth connection is **mandatory**. The installer must connect the earthing wire using the earthing terminal situated on the electric control board (yellow and green wire).

The power supply to the control circuit is shunted from the power line through an insulating transformer situated on the electric control board.

The control circuit is protected by suitable fuses or automatic breakers depending on the unit size.

4.2 Electrical connections of the circulation pump (if present)

For all LEW units a clean contact is provided on the electric board for powering a low-voltage remote control used to start the pump.



If it is an integral part of the supply, the pump must be started before the chiller and stopped after the latter (minimum recommended delay: 60 seconds). If it is connected to the terminal in the electric control board, this function is carried out by the built-in microprocessor.

4.3 Remote controls

If you wish to include a remote control for switching the unit on and off, you must remove the bridge between the contacts indicated in the wiring diagram and connect the remote ON/OFF control to the terminals themselves [see annexed wiring diagram], then enable the "REMOTE" function by means of the switch provided in the electric board.

4.4 Summer Winter Remote Switching [Heat pump version]

If you wish to include a remote control for summer/winter switching of the unit, you must remove the bridge between the contacts indicated in the wiring diagram and connect the remote ON/OFF control to the terminals themselves [see annexed wiring diagram], then enable the "REMOTE" function by means of the switch provided in the electric board.

5. STARTING UP

5.1 Preliminary checks

- Check that the cocks of cooling circuit, if present, are open.
- Check that the electrical connections have been made properly and that all the terminals **are securely tightened**. This check should also be included in a periodic six-month inspection.
- Check that the voltage at the RST terminals is $400\text{ V} \pm 5\%$ and **make sure** the yellow indicator light of the phase sequence relay is on. The phase sequence relay is positioned on the electric control board; if the sequence is not duly observed, it will not enable the machine to start.
- Make sure there are no refrigerant leaks that may have been caused by accidental impacts during transport and/or installation.
- Check the power supply to the crankcase heating elements, where present.



The heating elements must be turned on at least 12 hours before the unit is started. This function is carried out automatically when the main switch is off. Their function is to raise the T of the oil in the sump and limit the quantity of refrigerant dissolved in it.

To verify whether the heating elements are working properly, check the lower part of the compressors: it should be warm or in any case at a temperature $10 - 15\text{ }^{\circ}\text{C}$ higher than the ambient temperature.

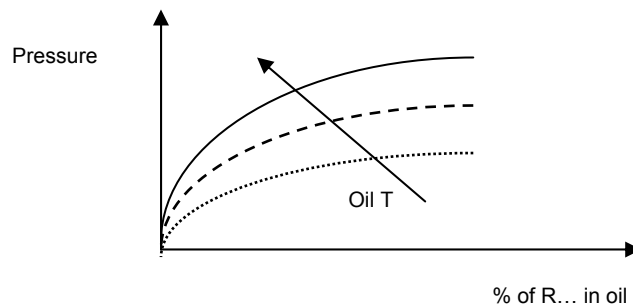

The diagram above illustrates a specific property [Charles' Law] of gases, which are more soluble in liquids as the pressure increases but less soluble as the temperature increases: if the oil in the sump is held at a constant pressure, an increase in oil temperature will significantly reduce the amount of refrigerant dissolved in it, thus ensuring that the lubricating function desired is maintained.

- Check that the plumbing connections have been properly made according to the indications given on the plates to be found on the unit itself (proper inlet and outlet connections).
- Make sure that the water circuit is duly bled to completely eliminate the presence of air: load the circuit gradually and open the air vent valves on the top part, which the installer should have set in place.

5.2 Start-up instructions for LEW water chillers

Water connections:

- Warning: the chiller is charged with HFC R410A – Group II EN 378 refrigerant (non-hazardous substances) conforming to the requirements of EEC regulation 2037/00.
- When making the plumbing connections, be sure to apply the inlet and outlet connections as indicated. In particular, be very careful **not** to invert condenser and evaporator circuits.
- **Apply gate valves on the water side so that the chiller may be isolated from the plumbing system and install a mesh filter (accessible for inspection) on both the evaporator and condenser sides.**
- Fill the water circuit, making sure to expel all the air present inside.

Electrical connections:

- Put on the main switch, turn the ½-turn locking screws of the electric enclosure and open it.
- Introduce the power cable 400/3/50+N through the hole provided on the left side of the unit and secure it in place with the cable holder.
- Connect the power supply and earthing wire to the terminals of the main switch.
- Put off switch “QF” of the compressor so as to be sure it will not start running in the wrong direction in the case of a phase sequence error.
- **Only with basic control mCH2** – Position the Local/Remote selector (SLR) situated at the top middle of the electric board on **LOCAL** and switch on the power by turning the main switch (IG) to ON.
- Check the phase sequence relay situated in the middle of the electric control board to make sure the phases are in the right sequence R-S-T; the **green** indicator light should go on: if it does not, disconnect the power supply to the unit from the external distribution board, invert two phases and repeat the check. **IN NO CASE SHOULD YOU TAMPER WITH THE WIRING DOWNSTREAM FROM THE MAIN SWITCH** since this may alter the correct sequence of other devices, e.g. pump(s).
- Put the compressor switch “QF” back on.
- Close the electric control board and lock it by means of the ½- turn locks.

Starting up:

- Check that all external cocks of the water circuit are open and water flows properly (the flow alarm should not be triggered).
- Put the main switch on the ON position.
 - The [external] pump will start immediately.
 - After 60 seconds the compressor will start.
- Check the water thermal differential (12-7°C to be detected by means of a thermometer on the inlet and outlet water pipes of the unit).
- Check that there are no leaks on the refrigerant side and water side.
- Using all the screws supplied, close the unit.

Use:

- always consult the USER manual and the µChiller or pCO1 manual provided with the unit when undertaking maintenance and/or advanced set-ups.

5.3 Starting operation

Before starting the unit, turn the main switch on, select the operating mode desired from the control panel and press the "ON" button on the control panel.

The unit will start up if enabled:

- by the safety devices of the water circulation pump/s
- by the flow switch (or differential pressure switch)
- by the T sensor measuring the temperature of the water returning from the system [chiller inlet]
- and no alarms have been triggered

If the unit fails to start up, check whether the service thermostat has been set according to the nominal values provided.



You should not disconnect the unit from the power supply during periods when it is inoperative but only when it is to be taken out of service for a prolonged period (e.g. at the end of the season).

5.4 Checks during operation

- Check the phase sequence relay on the control board to verify whether the phases occur in the correct sequence: if they do not, disconnect the unit from power supply and invert two phases of the incoming three-pole cable. **Never** attempt to modify internal electrical connections: any undue modifications will render the warranty null and void.
- Check that the temperature of the water entering the evaporator is close to the value set on the service thermostat.

5.5 Checking the refrigerant level

- After a few hours of operation, check whether the liquid level indicator has a green crown: a yellow colour indicates the presence of humidity in the circuit. In such a case the circuit must be dehumidified by qualified personnel.
- Large quantities of bubbles should not appear through the liquid level indicator. A constant passage of numerous bubbles may indicate that the refrigerant level is low and needs to be topped up. The presence of a few bubbles is however allowed, especially in the case of high-glide ternary mixtures such as HFC R410A.
- Also check that the end-of-evaporation temperature shown on the pressure gauge (refer to the pressure gauge scale for the refrigerant R410A) is about 4°C lower than the temperature of the water leaving the evaporator.
- Make sure the overheating of the cooling fluid is limited to between 5 and 8 °C. To this end:
 - 1) read the temperature indicated by a contact thermometer placed on the compressor intake pipe;
 - 2) read the temperature indicated on the scale of a pressure gauge likewise connected to the intake side; refer to the pressure gauge scale for the refrigerant R410A.The degree of overheating is given by the difference between the temperatures thus determined.
- Make sure that the undercooling of the cooling fluid is limited to between 3 and 5°C. To this end:
 - 1) read the temperature indicated by a contact thermometer placed on the condenser outlet pipe;
 - 2) read the temperature indicated on the scale of a pressure gauge connected to the liquid inlet at the condenser outlet; refer to the pressure gauge scale for the refrigerant R410A.The degree of undercooling is given by the difference between the temperatures thus determined.



Warning: all units of the LEW series are charged with R410A refrigerant except the versions with remote condenser which are charged with nitrogen. Any top-ups must be made using the same type of refrigerant. This operation is to be considered extraordinary maintenance work and must be performed by qualified personnel.



Warning: the refrigerant R410A requires "POE" polyolester oil of the type and viscosity indicated on the compressor rating plate. For no reason should oil of a different type be introduced into the oil circuit.

5.6 Stopping the unit

To stop the unit press the "OFF" button on the front panel.



Warning: do not stop the unit using the main switch. The latter device is used to disconnect the unit from the electricity supply when there is no passage of current, i.e. when the unit is already turned OFF.

Moreover, if you completely disconnect the unit from the electricity supply, the crankcase heating elements (where present) will receive no power, thereby jeopardising the integrity of the compressor the next time the unit is started.

6. OPERATING LIMITS

Operating limits of LEW chillers in relation to the outlet water temperature and water dew point. Applications with water T above the specified limits require the use of R134a refrigerant fluid (on request). For details please contact the local Galletti dealer.

□ Cooling only Units

Water temperature	Minimum	Maximum	Notes
Evaporator inlet	10	25	Without antifreeze products Below 15°C the condensation pressure control is required
Condenser inlet	15	45	

□ Heat pump units

Water temperature	Minimum	Maximum	Notes
Evaporator inlet (cooling mode)	10	25	Without antifreeze products
Condenser inlet (cooling mode)	15	45	Below 15°C the condensation pressure control is required
Evaporator inlet (*) (heating mode)	15	45	Without antifreeze products
Condenser inlet (*) (heating mode)	12	25	Without antifreeze products

(*) in heat pump operation heat exchangers work on reverse function.

6.1 Glycol solutions

It is possible to produce water at temperatures below 5°C and as low as -10°C using glycol solutions that lower the freezing point according to the following table:

Minimum temperature of water produced	5 °C	2°C	-1 °C	-5°C	-10 °C	
Percentage of ethylene glycol (in weight)	0 %	10 %	15%	25 %	30 %	35 %
Freezing temperature of mixture °C	0 °C	-4 °C	-8 °C	-14 °C	-18 °C	

Given an equal volumetric flow rate of water, pressure drops will depend on the percentage of glycol, as shown in the following table:

Percentage of ethylene glycol (in weight)	0 %	10 %	15%	25 %	30 %	35 %
Pressure drop change	0 %	+12 %	+ 21 %	+43 %	+55 %	

6.2 Operating limits

- ❑ thermal carrier: fluid water or glycolated water and antifreeze mixtures max. 35%
- ❑ maximum water operating pressure: 3 bars
- ❑ Maximum operating P – High pressure side = 42 bar-r
- ❑ Maximum operating T = 45°C
- ❑ Minimum operating T = -10°C
- ❑ Maximum operating P – Low pressure side = 30 bar-r (*)
- ❑ Supply voltage: = +/- 10% of rating plate voltage
- ❑ Maximum stocking T = + 50°C
- ❑ Minimum stocking T = -10°C (limit imposed by the built-in electronic components)

(*) this value can be reached only in storage conditions and determines the refrigerant saturation pressure of 30 bar-r on the low pressure side of the circuit, a value which in fact defines the limits.

6.3 Water flow to the evaporator

The nominal flow rate is based on a thermal differential of 5° C between inlet and outlet water, in relation to the cooling capacity provided at the nominal water temperatures (12/7 °C).

The maximum allowed flow rate is associated with a thermal differential of 3 °C. Higher flow rate values cause too big pressure drops.

The minimum allowed flow rate is associated with a thermal differential of 8 °C. Lower flow rates could cause excessively low evaporation temperatures, which would trigger the safety devices and cause the unit to stop.

7. SETTING OPERATING PARAMETERS

7.1 Generalities

All the control devices are set and tested in the factory before the unit is dispatched. However, after the unit has been in service for a reasonable period of time you can perform a check on the operating and safety devices. The setting values are shown in the Tables I and II.



All servicing of the equipment is to be considered extraordinary maintenance and may be carried out SOLELY BY QUALIFIED TECHNICIANS: incorrect settings may cause serious damage to the unit and injury to persons.

The operating parameters and control system settings configurable by means of the microprocessor control are password protected if they have a potential impact on the integrity of the unit.

TABLE I - SETTING OF CONTROL DEVICES

CONTROL DEVICE		SET POINT	DIFFERENTIAL
Service thermostat [Cooling]	°C	12	2
Service thermostat [H]	°C	40	2

TABLE II - SETTING OF SAFETY-CONTROL DEVICES

CONTROL DEVICE		ACTIVATION	DIFFERENTIAL	RESETTING
Antifreeze thermostat	°C	+4	2	Automatic
Maximum pressure switch IV PED	bars	42,0	-	Manual
High pressure relief valve IV PED	bars	44,0	-0 / +10%	-
Minimum pressure switch	bars	1,5	1,0	Automatic
Modulating condensation control device [optional]	bars	18	10	-
Time lapse between two starts of the same compressor	s	480	-	-
Delay in flow switch alarm	s	20	-	-
Delay in low pressure alarm	s	1	-	-

The high pressure switch stops the compressor when the outlet pressure exceeds the set value.



Warning: do not attempt to change the setting of the maximum pressure switch. Should the latter fail to trip in the event of a pressure increase, the pressure relief valve will open.

The high pressure switch must be **manually reset**; this is possible only when the pressure falls below the set differential (see Table II).

7.3 Minimum pressure switch

The low pressure switch stops the compressor when the intake pressure falls below the set value for more than 120 seconds.

The switch is automatically reset when the pressure rises above the set differential (see Table II).

7.4 Service thermostat

This device permits to enable and disable the compressors' operation as a function of the reading of the inlet water temperature of the chilling unit [return from the system]. For further details, refer to the microprocessor control section in the manual.

7.5 Antifreeze thermostat

The antifreeze probe is located at the evaporator outlet and stops the compressor when the temperature goes below the set limit value. Together with the flow switch and low pressure switch, this device protects the evaporator from the risk of freezing as a result of faults in the water circuit. For further details, refer to the microprocessor control section in the manual.

7.6 Anti-recycle timer

The function of the timer is to prevent excessively frequent compressor starts and stops. This device imposes a minimum time lapse of 480 seconds between two compressor starts. For further details, refer to the microprocessor control section in the manual.



Never attempt to change the delay set in the factory: wrong settings could cause serious damage to the unit.

8. MAINTENANCE

The only tasks to be performed by the end user are turning the chillers on and off and switching them between the cooling and heating functions as the seasons change.

All other operations are to be considered maintenance work and must thus be carried out by qualified personnel trained to do their job in observance of current laws and regulations.

8.1 Warnings



All the operations described in this chapter MUST ALWAYS BE PERFORMED BY QUALIFIED PERSONNEL.



Before carrying out any work on the unit or accessing internal parts, make sure you have disconnected it from the mains electricity supply.



The upper part and the outlet pipe of the compressor reach high temperatures. Be especially careful when working in the surrounding area with the panels off.



Be especially careful when working in proximity to finned coils of the units since the 0.11 mm-thick aluminium fins can cause superficial injuries due to cuts.



After completing maintenance jobs, always replace the panels enclosing the units and secure them with the fastening screws provided.

8.2 Generalities

To guarantee a constantly satisfactory performance over time, it is advisable to carry out routine maintenance and checks as described below.

Operations	Frequency
<ul style="list-style-type: none"> • Check the efficiency of all the control and safety devices. 	Once a year

- Check the terminals on the electric control board and compressor terminal boards to ensure that they are securely tightened. The movable and fixed contacts of the circuit breakers must be periodically cleaned and replaced whenever they show signs of deterioration. Once a year
- Check the refrigerant level by means of the liquid level indicator. Every 6 months
- Check the oil levels through the windows provided on the compressor crankcases. Every 6 months
- Check the water circuit for leaks. Every 6 months
- If the unit is to remain out of service for a long time, drain the water from the pipes and heat exchanger. This is indispensable if during the period of quiescence the ambient temperature is expected to fall below the freezing point of the fluid used. Every 6 months
- Check whether the water in the circuit needs to be replenished. Every 6 months
- Check the efficiency of the flow switch or differential pressure switch. Every 6 months
- Clean the metal mesh filters mounted externally on the water pipes. First start-up
- Check the humidity indicator (green=dry, yellow=humid) on the liquid level indicator; if the indicator is not green as shown on the indicator sticker, replace the filter. Every 6 months

8.3 Repairing the Cooling Circuit



Warning: while performing repairs on the cooling circuit or maintenance work on the compressors, make sure the circuit is left open for as little time as possible. Even if briefly exposed to air, ester oils tend to absorb large amounts of humidity, which results in the formation of weak acids.

If the cooling circuit has undergone any repairs, the following operations must be carried out:

- tightness test;
- emptying and drying of the cooling circuit;
- charging with refrigerant.



If the system has to be drained, always recover the refrigerant present in the circuit using suitable equipment; the refrigerant should be handled exclusively in the liquid phase.

8.4 Tightness test

Fill the circuit with anhydrous nitrogen supplied from a tank with a pressure-reducing valve until the pressure rises to 28 bars.



During the pressurisation phase, do not exceed a pressure of 28 bars-r on the low pressure side.

The presence of any leaks must be determined using special leak detectors. Should any leaks be detected during the test, empty out the circuit before repairing the leaks with suitable alloys.



Do not use oxygen in the place of nitrogen as a test agent, since this would cause a risk of explosion.

8.5 Hard Vacuum and Drying of Cooling Circuit

To achieve a hard vacuum in the cooling circuit it is necessary to use a pump capable of generating a high degree of vacuum, i.e. 150 Pa of absolute pressure with a capacity of approximately 10 m³/h. If such a pump is available, one evacuation will normally suffice to achieve an absolute pressure of 150 Pa.

If there is no such vacuum pump available, or whenever the circuit has remained open for long periods of time, you are strongly recommended to adopt the triple evacuation method. This method is also recommended when there is a presence of humidity within the circuit.

The vacuum pump should be connected to the inlets.

The procedure to be carried out is as follows:

- Evacuate the circuit until you reach an absolute pressure of at least 350 Pa. At this point inject nitrogen into the circuit until you reach a relative pressure of about 1 bar.
- Repeat the step described above.
- Carry out the step described above for the third time, but in this case attempting to reach the hardest vacuum possible.

Using this procedure you can easily remove up to 99% of pollutants.

8.6 Recharging with refrigerant R410A

- Connect the tank of refrigerant gas to the male 1/4 SAE inlet situated on the liquid line after discharging a little gas to eliminate air in the connection pipe.
- Fill with refrigerant in liquid form until you reach 75% of the total charge.
- Then connect to the inlet on the pipe between the thermostatic valve and evaporator and complete the charging process with the refrigerant in liquid form until no more bubbles can be seen on the liquid level indicator and the operating parameters specified in this manual have been reached.



Introduce refrigerant through the inlet in the liquid line.



A unit that was originally charged with R410A in the factory cannot be charged with R22 or other refrigerants without the written authorisation of Galletti.

8.7 Environmental protection

The law implementing the regulations [reg. EEC 2037/00] which govern the use of ozone-depleting substances and greenhouse gases bans the dispersal of refrigerant gases in the environment and requires whoever is in their possession to recover them and, at the end of their useful life, either to return them to the dealer or take them to a suitable waste disposal facility.

The refrigerant HFC R410A is not harmful to the ozone layer but is included among the substances responsible for the greenhouse effect and thus falls within the scope of the aforesaid regulations.



Therefore, special care should be taken when carrying out maintenance work to minimise refrigerant leaks.

9. TROUBLESHOOTING

On the next pages you will find a list of the most common causes that may cause the chilling unit to fail or malfunction. These causes are broken down according to easily identifiable symptoms.



You should be extremely careful when attempting to implement any of the possible remedies suggested: overconfidence can result in injuries, even serious ones, to inexperienced individuals. Therefore, once the cause has been identified, you are advised to contact the manufacturer or a qualified technician for help.

FAULT	Possible causes	Corrective actions
The unit does not start	No power supply.	Check that power is being supplied both to the primary and auxiliary circuits.
	The electronic card is cut off from the power supply.	Check the fuses.
	Alarms have been triggered.	Check whether any alarms are signalled on the microprocessor control panel, eliminate the causes and restart the unit.
	The phase sequence is wrong.	Invert two phases in the primary power line after disconnecting them upstream from the unit.
The compressor is noisy	The compressor is rotating in the wrong direction.	Check the phase sequence relay. Invert the phases on the terminal board after disconnecting the unit and contact the manufacturer.
Presence of abnormally high pressure	Insufficient flow of water to the condenser.	Check for any clogging in the water circuit.
		Check the compressor inlet water T.
	Presence of air in the refrigerant circuit, as revealed by the presence of bubbles in the flow indicator also with undercooling values exceeding 5 °C.	Check the condensation control device [optional].
		Drain and pressurise the circuit and check for leaks. Evacuate slowly [for more than 3 hours until reaching a pressure of 0.1 mBar and then recharge in the liquid phase.

FAULT	Possible causes	Corrective actions
Presence of abnormally high pressure	Unit overcharged, as revealed by an undercooling of more than 8°C.	Drain the circuit.
	Thermostatic valve and/or filter obstructed. These symptoms may also occur in the presence of an abnormally low pressure.	Check the temperatures upstream and downstream from the valve and filter and replace them if necessary.
	Insufficient flow of water in the case of heat pump operation.	Check the water circuit for pressure drops and/or whether the pump is working properly [direction of rotation]. Check the outgoing water T and make sure it is less than or equal to 50°C.
Low condensation pressure	Transducer fault.	Check the setting of the condensation control device [opt.].
	Water T too low.	Install the condensation control device.
Low evaporation pressure	Insufficient flow of water.	Check whether the pumps are rotating in the right direction. Check the water system for pressure drops.
	Malfunctioning of thermostatic valve.	Warming the bulb with your hand, check whether the valve opens and adjust it if necessary. If it does not respond, replace it.
	Filter clogged.	Pressure drops upstream and downstream from the filter should not exceed 2°C. If they do, replace the filter.
	Low condensation T.	Check the efficiency of the condensation control device [where present].
	Low level of refrigerant.	Check the refrigerant level by measuring the degree of undercooling; if it is below 2°C replenish the charge.
The compressor does not start	The internal thermal protection device has tripped.	In the case of compressors equipped with a protection module, check the thermal contact. Identify the causes after restarting.
	The circuit breakers or line fuses have been tripped by a short circuit.	Pinpoint the cause by measuring the resistance of the individual windings and the insulation from the casing before restoring power.
	One of the high or low pressure switches has tripped.	Check on the microprocessor, eliminate the causes.
	The phases have been inverted in the distribution compartment.	Check the phase sequence relay, then invert the phases upstream from the main switch.
High evaporation pressure	Water T too high.	Check the thermal load and/or efficiency of the thermostat function.
		Check the efficiency of the thermostatic valve.



40010 Bentivoglio (BO)
Via Romagnoli 12/a
Tel. 051/8908111
Fax. 051/8908122
www.galletti.it

Company UNI EN ISO 9001 and OHSAS 18001 certified